

INSTALLATION – UNIVERSAL TAPER LOCK BUSHING

The following procedure is recommended for all shaft mounted units using the universal taper lock bushing and standard torque arm. All taper lock bushing kits are supplied with bushing, pull-up ring, mounting hardware, snap-in centering ring, retaining rings, and shaft key. Refer to the Helical Bevel catalog for torque arm mounting and customer shaft dimensions when using the universal taper lock bushing mounting option. Refer to illustration below when installing units with universal taper lock bushings. Note that the shaft cover kit is sold separately.

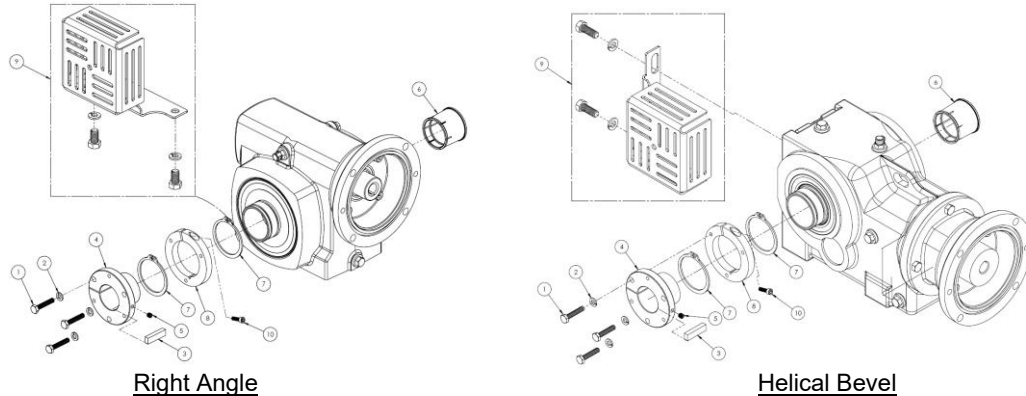

| Item No. | Description | Qty | Item No. | Description | Qty |
|----------|--------------------|-----|----------|-----------------------------------|-----|
| 1 | Hex Head Screw | 3 | 6 | Snap-In Centering Ring | 1 |
| 2 | Lock Washer | 3 | 7 | External Retaining Ring | 2 |
| 3 | Shaft Key | 1 | 8 | Pull-up Ring | 1 |
| 4 | Taper Lock Bushing | 1 | 9 | Shaft Cover Kit (sold separately) | 1 |
| 5 | Set Screw | 1 | 10 | Socket Head Screw | 1 |

Tools Required.

- Torque Wrench capable of registering 1.5-50 ft-lbs (18-600 in-lbs)
- 7/16" Socket for 1/4-20 Hex Head Screws
- 1/2" Socket for 5/16-18 Hex Head Screws
- 9/16" Socket for 3/8-16 Hex Head Screws
- 5/32" Hex Bit Socket for 10-32 Socket Head Screw
- 3/16" Hex Bit Socket for 1/4-28 Socket Head Screw
- 1/8" Allen Key for 1/4-20 Set Screw

1. Clean driven shaft extension and output bore of the unit.
2. Determine which side of the unit is to be the location of the taper lock bushing and which side is going to be the location of the snap-in centering ring.
3. Install the snap-in centering ring.

WARNING: Once the snap-in centering ring is installed, it cannot be removed without destroying it and a new one must be obtained from the factory.

4. Install the external retaining ring in the groove closest to the housing on the side that is to be the location of the taper lock bushing. Install the pull-up ring – **DO NOT TIGHTEN THE SOCKET HEAD SCREW IN THE PULL-UP RING!** Install the second external retaining ring so that the pull-up ring is located between the two retaining rings. The pull-up ring should be able to rotate freely at this point.

5. Install the supplied shaft key.

CAUTION: Taper lock bushings are meant to be dry mounted. **DO NOT USE** lubricants, anti-seize, or anti-fretting compounds on the bushing and shaft mounting area.

6. Align tapped holes in pull-up ring with the through holes in tapered bushing.
7. Insert hex head screws (supplied) through the holes in the tapered bushing and thread loosely into tapped holes in pull-ring.
8. Position assembly on driven shaft. Make sure the key is in contact with the full length of the tapered busing. Tighten hex head screws in a progressive and uniform manner to the torque value listed below.

| Right Angle Unit Size | Helical Bevel Unit Size | Screw Size | Tightening Torque |
|-----------------------|-------------------------|------------|-------------------|
| SS2206/2238/2262 | SSK33/SSK34/K04 | 1/4-20 | 9 ft-lbs |
| SS2325 | SSK36/K06 | 5/16-18 | 15 ft-lbs |
| N/A | SSK37/K07 | 3/8-16 | 30 ft-lbs |

WARNING: The tightening force on the hex head screws is multiplied many times by the wedging action of the tapered surface. If extreme tightening force is applied, or if a lubricant is used, bursting pressures will be created in the hollow shaft hub of the mating part.

9. Install set screw over shaft key and tighten to **9 ft-lbs**.
10. Tighten the socket head screw in the pull-up ring to the torque listed below.

| Right Angle Unit Size | Helical Bevel Unit size | Screw Size | Tightening Torque |
|-----------------------|---------------------------|------------|-------------------|
| SS2206/2238/2262/2325 | SSK33/SSK34/K04/SSK36/K06 | 10-32 | 3 ft-lbs |
| N/A | SSK37/K07 | 1/4-28 | 9 ft-lbs |

11. Anchor the unit to a secure point on the structure by means of the torque arm.
12. Fit guards in accordance with the relevant state and local safety regulations.
13. Check the oil level and install the breather vent (if required) as described in **LUBRICATION**.
14. Install the shaft cover (sold separately).
15. Install the motor as described in **MOTOR INSTALLATION**.

REMOVAL – UNIVERSAL TAPER LOCK BUSHING

WARNING: Hot oil or gear units can cause severe burns. Use extreme care when removing lubrication plugs and vents.

WARNING: Make certain that the power supply is disconnected before attempting to service or remove any components. Lock out the power supply and tag it to prevent unexpected application of power.

1. Remove shaft cover (if installed).
2. To remove the unit, loosen set screw over the shaft key.
3. Loosen the socket head screw in the pull-up to allow it to rotate freely.
4. Loosen and remove the hex head screws. These will be used as jack screws in the tapped holes in the taper lock bushing.
5. Insert hex head screws in the tapped holes in the taper lock bushing making sure the pull-up ring is oriented such that the hex head screws push against it. Progressively tighten each one until the taper bushings comes loose form the reducer output shaft.
6. Remove the taper lock bushing.
7. Remove unit using caution and proper lifting techniques.